

DOUBLE DROP SERIES



35-55 TON MODELS



DOUBLE DROP



Sliding pin or swinging teardrop connections available for enhanced tractor compatibility.



Ultra-low deck height for unmatched clearance and simplified route logistics. (pictured with optional aluminum pullouts)



Multiple gooseneck options – mechanical, hydraulic or fixed – customized to your hauling needs.

DOUBLE DROP

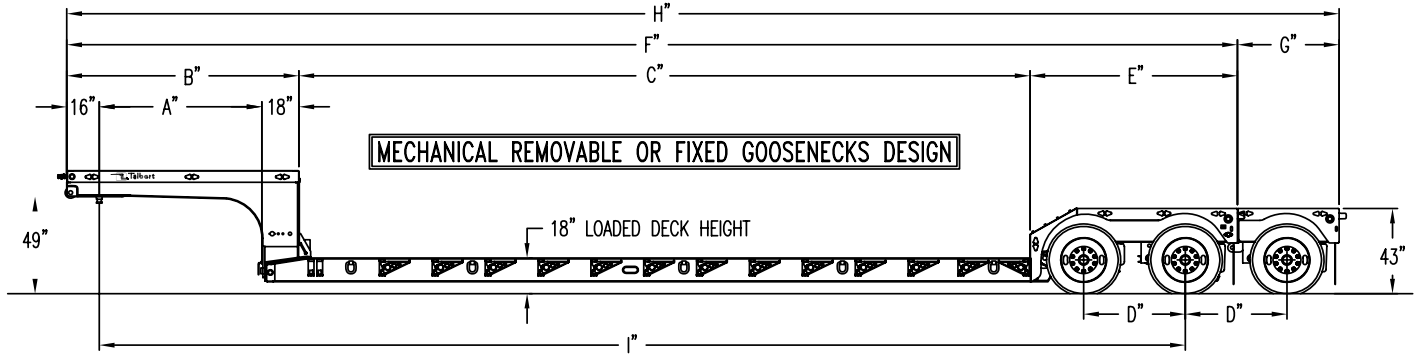

"A" Gooseneck Radius	"B" Gooseneck Length	"C" Deck Length	"D" Axle Spacing	"E" Bridge Length	"F" Trailer Length 2 Axle	"G" 3 Axle Length	"H" Trailer Length 3 Axle	"I" Kingpin to 2 Axle
80 in.	9 ft. 6 in.	30 ft. 0 in.	50 in.	8 ft. 6 in.	48 ft. 0 in.	4 ft. 2 in.	52 ft. 2 in.	44 ft. 6 in.
80 in.	9 ft. 6 in.	29 ft. 0 in.	54 in.	8 ft. 10 in.	47 ft. 4 in.	4 ft. 6 in.	51 ft. 10 in.	43 ft. 10 in.
80 in.	9 ft. 6 in.	29 ft. 0 in.	60 in.	9 ft. 4 in.	47 ft. 10 in.	5 ft. 0 in.	52 ft. 10 in.	44 ft. 4 in.

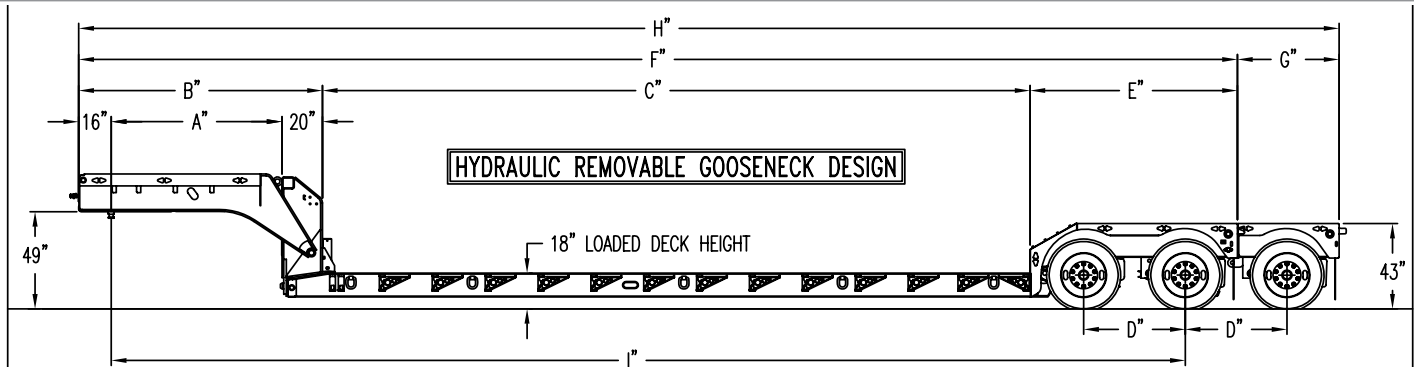

"A" Gooseneck Radius	"B" Gooseneck Length	"C" Deck Length	"D" Axle Spacing	"E" Bridge Length	"F" Trailer Length 2 Axle	"G" 3 Axle Length	"H" Trailer Length 3 Axle	"I" Kingpin to 2 Axle
84 in.	10 ft. 0 in.	29 ft. 0 in.	50 in.	8 ft. 6 in.	47 ft. 6 in.	4 ft. 2 in.	51 ft. 8 in.	44 ft. 0 in.
84 in.	10 ft. 0 in.	29 ft. 0 in.	54 in.	8 ft. 10 in.	47 ft. 10 in.	4 ft. 6 in.	52 ft. 4 in.	44 ft. 4 in.
84 in.	10 ft. 0 in.	28 ft. 0 in.	60 in.	9 ft. 4 in.	47 ft. 4 in.	5 ft. 0 in.	52 ft. 4 in.	43 ft. 10 in.

Gooseneck Design

HRG- Hydraulic Removable

SRG- Mechanical Removable

FG- Fixed

- Capacity: 30-55 Ton
- Full Capacity Evenly Distributed
- Full Capacity Less 10,000 lbs. In 10 in. 0 ft.
- Rollers At Front Of Gooseneck (SRG)
- Full Width Gooseneck Platform; 1-1/8 in. Shiplap Apitong, 3 Lashing Slots Each Side And Mud Flap Skirts
- Deck Height: 18 in. Loaded
- Road Clearance: 6 in. Loaded
- Four (4) Beam Design (HRG/SRG)
- 1-1/2 in. Apitong Flooring Outside Mainbeams
- 12 in. Outriggers (HRG/SRG)
- 10 Lash Rings (5 Each Side Of Deck) (HRG/SRG)
- Cross Members On 24 in. Centers
- Tapered Bridge Ramp With Traction Bars (HRG/SRG)
- Full Width Rear Bridge Platform With 1-1/8 in. Shiplap Apitong And 4 Lashing Slots Each Side
- Air Suspension With Manual Raising And Lowering Hand Valve
- Axles: 25,000 lb. Capacity
- Brakes: 16-1/2 in. x 7 in. With Automatic Slack Adjusters
- Tires: 255/70R22.5 (H) 16PR
- Wheels: Steel Disc, Hub Piloted, Outboard Mounted Drums
- Lights: 12 Volt DOT L.E.D, Rubber Mounted With Sealed Harness
- Options: 3rd Axle (Removable Or Fixed)
- Estimated Empty Weight: Starting At 14,920 lbs.
- Talbert Red Or Black Paint

Various Options Available Upon Request. Specifications Subject To Change Without Notice.

Dealer:



Talbert Manufacturing Inc. \ 1628 W. State Road 114 \ Rensselaer IN 47978 \ 800-348-5232 \ Fax: 219-866-7060

sales@talbertmfg.com \ www.talbertmfg.com

0312-4k PUB 211B